

I-2532 & I-2533 FAQ

Q1 · What is the difference between I-2532s and I-2533s? (2011/1/5,Bear)	3
Q2 · How to calculate the working distance and the device numbers on the same CAN network while using I-2532s? (2011/1/5,Bear)	4
Q3 · May I mix I-2532s and I-2533s in the same CAN network? (2011/1/5,Bear)	5
Q4 · If some bus error happens on one side of I-2532s, is there any affection to my system? (2011/1/5,Bear).....	7
Q5 · If some error happens on one side of I-2533s, is there any affection to my system? (2011/1/5,Bear).....	7
Q6 · The Rx and Tx LED are flashing on one side of the I-2532. And the Rx and Tx LED are off on the other side of the I-2532. What happen would make this condition? (2012/06/25,Johney) The LED is like the diagram below.....	8
Q7 · What is the relationship of some error conditions and the Rx and Tx LED of the I-2532? (2012/06/25,Johney).....	10
Q8: Why the I-2532 modules stop to convert the CAN single to fiber single after a long time test? (2013/12/10, Alan)	12





Q1 、 What is the difference between I-2532s and I-2533s?

(2011/1/5,Bear)

Ans: Both I-2532s and I-2533s are the CAN to fiber optical converter. The main differences between these two kinds of products are the CAN message filter and the fiber working distance under different baud. As you know, the CAN bus working distance is affected by the baud of the CAN bus no matter what transformation media you use. The higher baud you use, the shorter working distance the fiber is. I-2532s follows this rule, but I-2533s evades this issue by the firmware inside. If the fiber quality is good enough, the fiber working distance of I-2533s can be reached to 2 km. By means of the firmware inside, I-2533s can provide two special functions, the CAN message filter and bridge two CAN networks with different baud, which can't be practiced by I-2532s. But the downside to the firmware is the baud selection before using I-2533s. By contrast, I-2532s is auto-baud. The comparison table of these products is shown below.

Product	I-2532	I-2533
Firmware Inside	X	O
Fiber Working Distance	Depended on CAN baud	Max. 2 km
CAN Bus Working Distance	Depend on CAN baud and the length of the fiber	Depend on CAN baud
CAN Message Filter	X	O
Baud Selection	Auto-baud	By rotary switch or utility tool
Fiber Broken Detect	X	O

(2011/1/5,Bear)

Q2 · How to calculate the working distance and the device numbers on the same CAN network while using I-2532s? (2011/1/5,Bear)

Ans: The I-2532 is a repeater. It can recover the damaged signal to original one, but the total working distance of the fiber and the CAN bus is reduced because of the propagation delay and the thrust of I-2532s. Because of the propagation delay, the relationship between the CAN bus working distance and baud are shown below.

Baud rate (bit/s)	Max. Bus length (m)
500 K	100
250 K	250
125 K	500
50 K	1000

The thrust of I-2532s decide how many devices the I-2532 can drive and how long the CAN message can be transmitted in the CAN bus. Besides, the propagation delay of I-2532s influences the total length of the fiber cable and CAN cable. When you want to know the total working distance of your system, both of these two points must be considered. For example, assume that your system looks like the following figure.

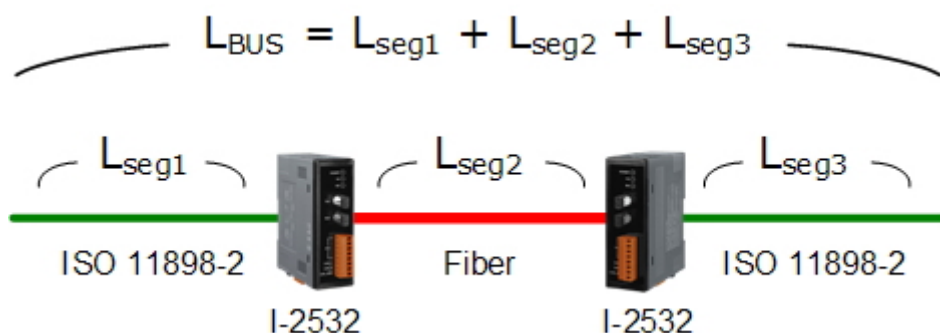

If you need to use the 125 kbps baud, the total working distance (L_{BUS}) is 250m because of the propagation delay. Therefore, the maximum length of the L_{BUS} is 450m ($500m - 25m * 2 = 450m$, 25m is the equivalent of the propagation delay for each I-2532). Assume that the lengths of L_{seg2} and L_{seg3} in your system are 130m respectively and the cross-section of your CAN bus cable is AWG23, you can look up the table below to find the relationship between the CAN bus length and the device numbers. The maximum length of the L_{seg1} is 190m ($450m - 130m - 130m = 190m$). According to the following table, if you need to have 64 devices on the segment of L_{seg1} , the maximum length of the L_{seg1} is reduced to 170m. If the length of the L_{seg1} must be 190m, you can only have less than 32 devices on the segment of L_{seg1} .

Wire Cross-Section [mm ²]	The maximum segment length [m] under the case of specific node number in this segment			
	16 Nodes	32 Nodes	64 Nodes	100 Nodes
~0.25 (AWG23)	< 220	< 200	< 170	< 150
~0.5 (AWG20)	< 390	< 360	< 310	< 270
~0.8 (AWG18)	< 590	< 550	< 470	< 410
~1.3 (AWG16)	<980	<900	<780	<670

(2011/1/5,Bear)

Q3 · May I mix I-2532s and I-2533s in the same CAN network?

(2011/1/5,Bear)

Ans: Because the hardware architectures of I-2532s and I-2533s are different, you can't couple them together. If I-2533s are coupled with I-2533s and I-2532s are coupled with I-2532s in your system, it works normally. The following 4 figures indicate the correct implement of I-2532s and I-2533s.

1. Use a couple of I-2532s. The working distance of fiber will be shortened according to the baud of CAN bus.

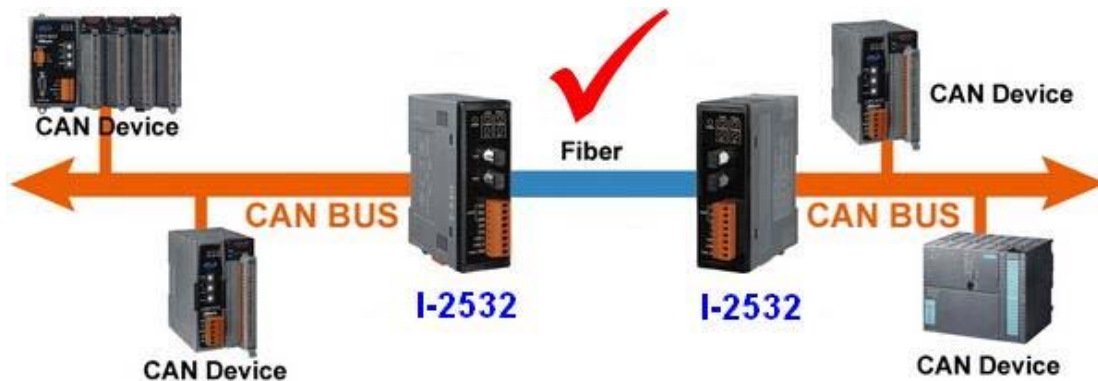

2. Use a couple of I-2533s. The working distance of fiber is fixed. The maximum length is 2 km.

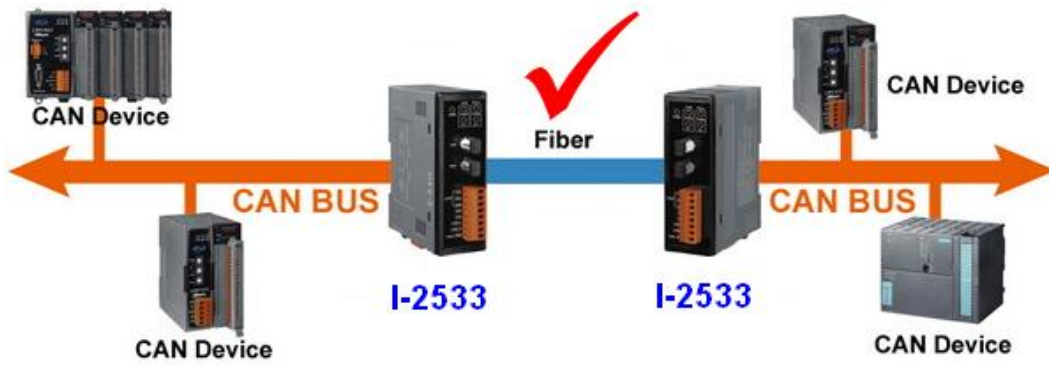

3. Mix the implement of I-2532s and I-2533s. This architecture can't work.

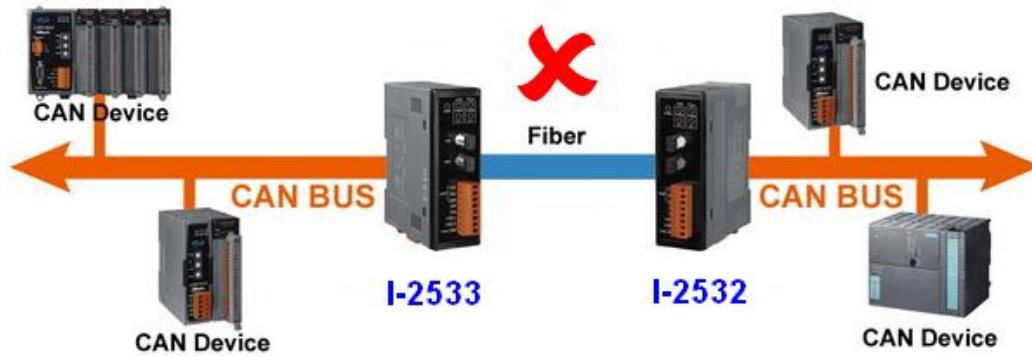

4. Use a couple of I-2533s and a couple of I-2532s. The total working distance of fiber and CAN bus will be shortened according to the baud of CAN bus.

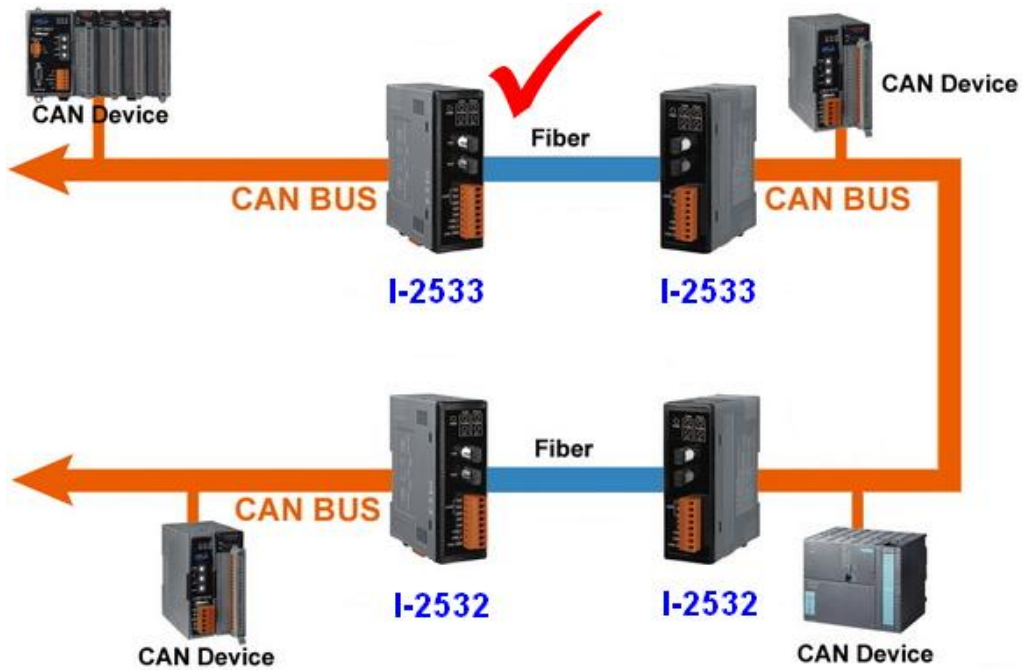

(2011/1/5,Bear)

Q4 · If some bus error happens on one side of I-2532s, is there any affection to my system? (2011/1/5,Bear)

Ans: When you apply I-2532s in your CAN system, you need a couple of I-2532s and the system architecture may be looked like as below.

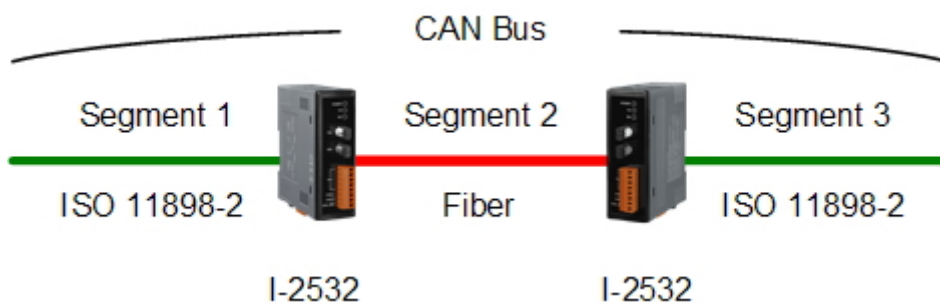

If some bus error, except the short of the CAN_H and CAN_L, happens in the Segment 1, the CAN error message will be transferred to the Segment 3 and vice versa. The short of the CAN_H and CAN_L have no affection to another Segment. That is, the CAN data exchange in the Segment 1 works normally even if the CAN_H and CAN_L are shorten in the Segment 3. The CAN message transformation between Segment 1 and Segment 3 is terminated while the Segment 2 is broken.

(2011/1/5,Bear)

Q5 · If some error happens on one side of I-2533s, is there any affection to my system? (2011/1/5,Bear)

Ans: When you apply I-2533s in your CAN system, you need a couple of I-2533s and the system architecture may be looked like as below.

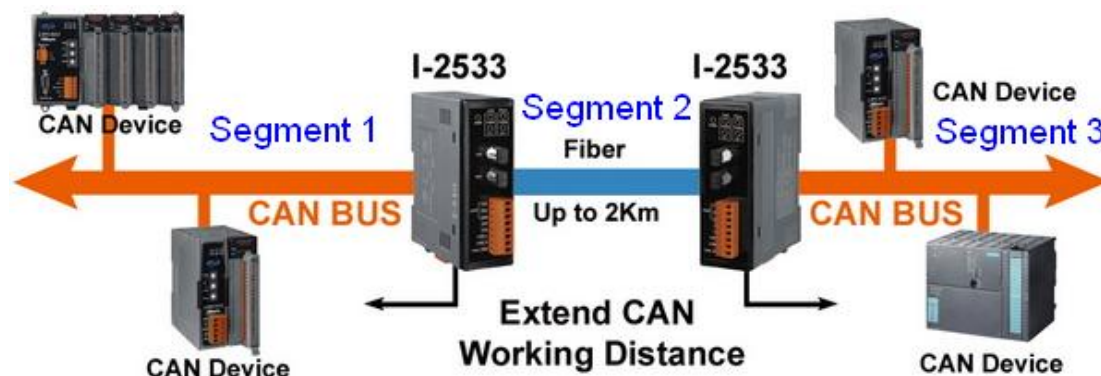

If some bus error, including the short of the CAN_H and CAN_L, happens in the

Segment 1, the CAN data exchange in the Segment 3 works normally, and vice versa. The CAN message transformation between Segment 1 and Segment 3 is terminated while the Segment 2 is broken. In this case, the fiber error indicator is turned on in one of the I-2533s. You can check the indicator to know the fiber condition and do something if necessary.

(2011/1/5,Bear)

Q6 · The Rx and Tx LED are flashing on one side of the I-2532. And the Rx and Tx LED are off on the other side of the I-2532. What happen would make this condition? (2012/06/25,Johney)
The LED is like the diagram below.

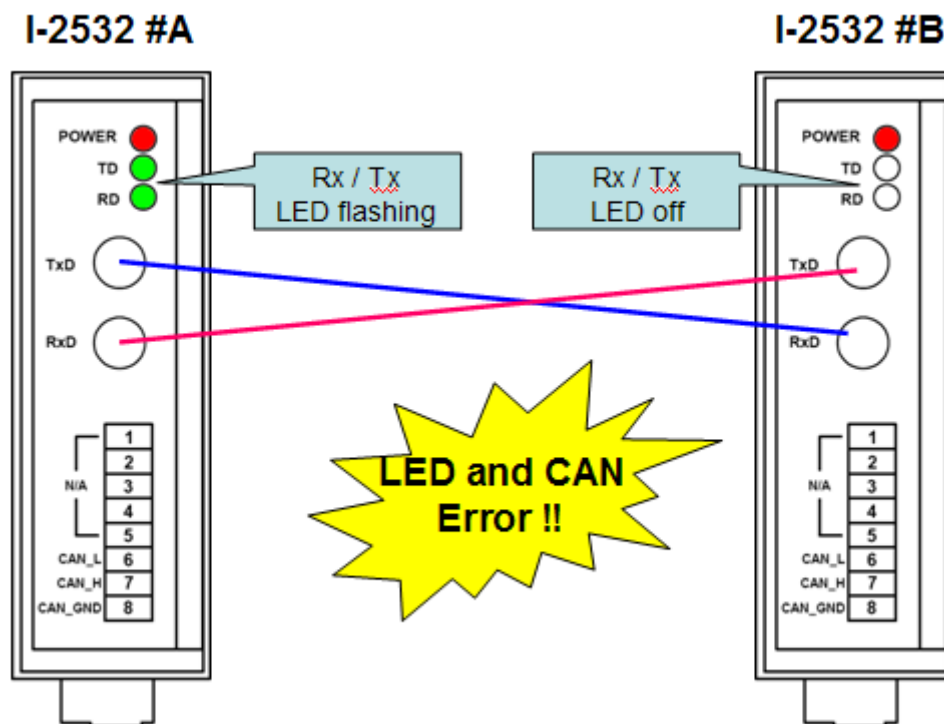

Ans:

1. Maybe the fiber cable is broken. Check the fiber cable.

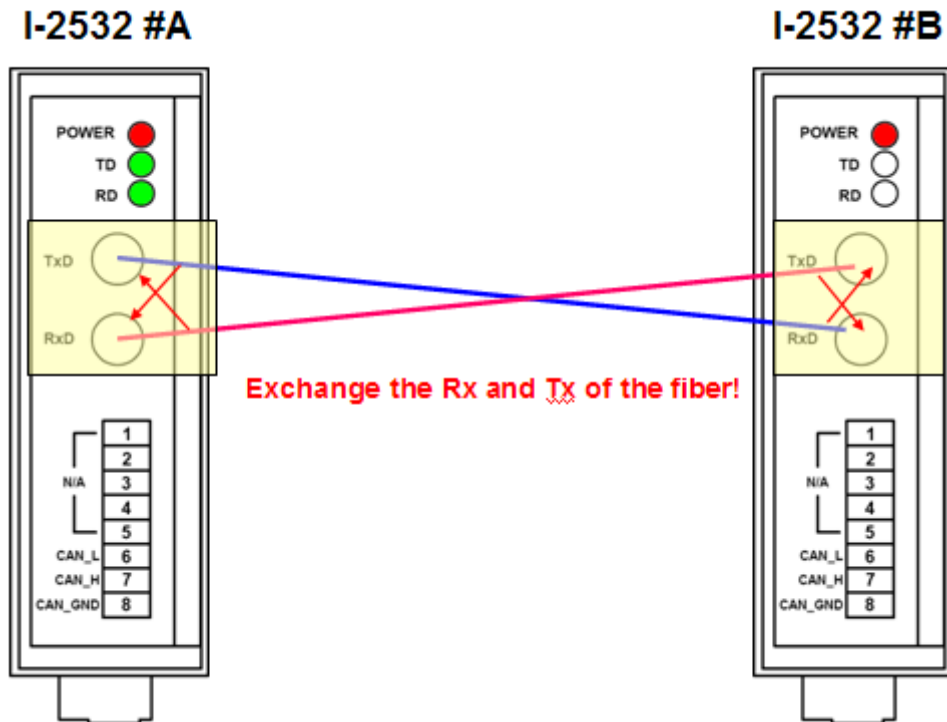

If the users find out the condition changed, the fiber maybe broken.

2. Maybe the I-2532 module is broken. Check the I-2532 module.

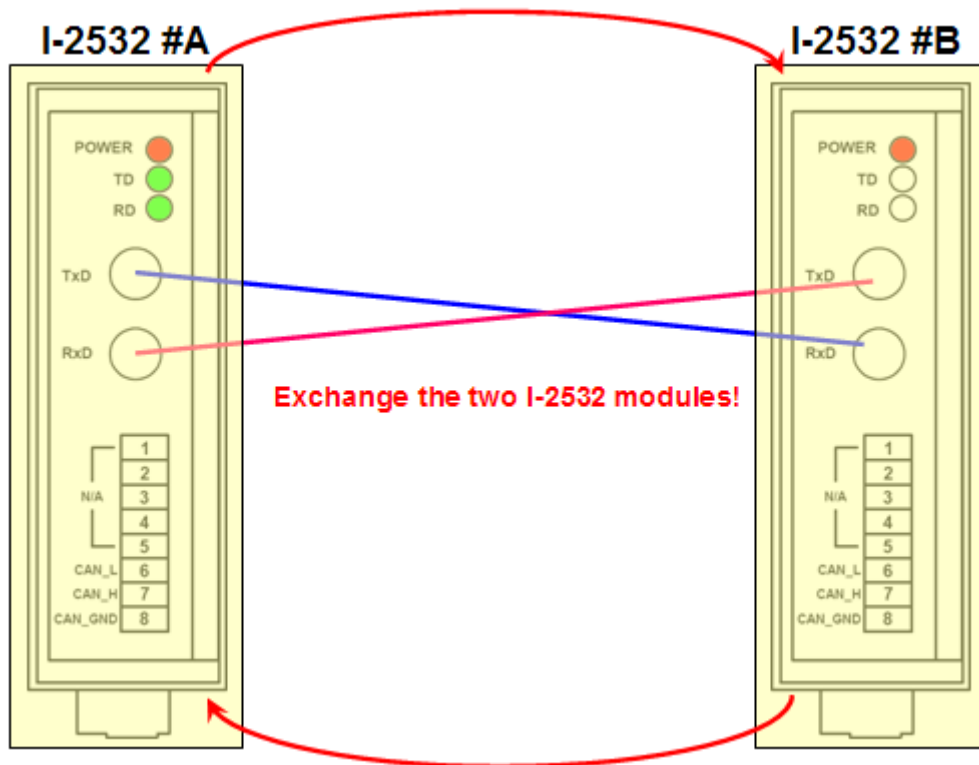

If the users find out the condition changed, the I-2532 module maybe broken.

(2012/06/25,Johney)

Q7 · What is the relationship of some error conditions and the Rx and Tx LED of the I-2532? (2012/06/25, Johney)

Ans :

(1) Fiber cable with wrong connection.

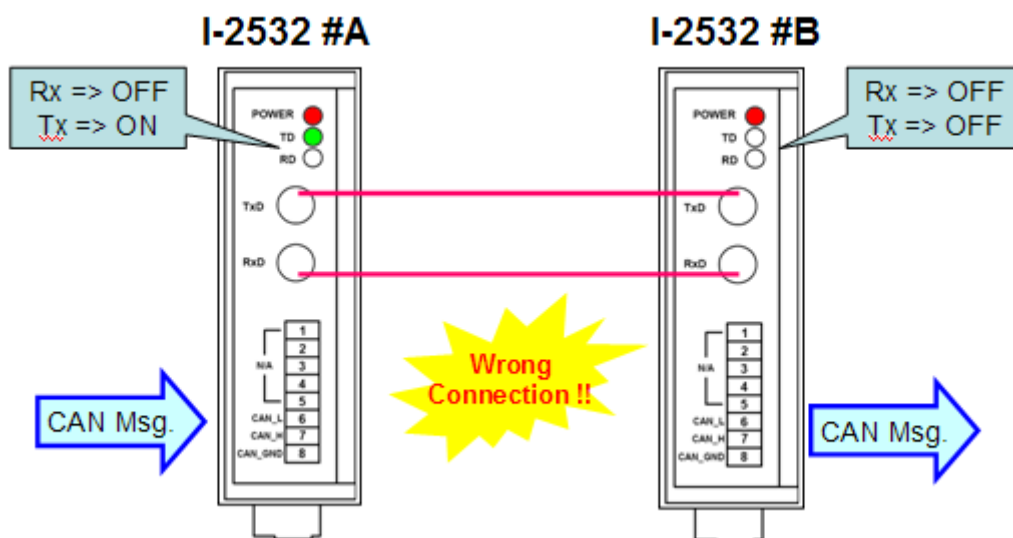

(2) CAN bus is disconnected.

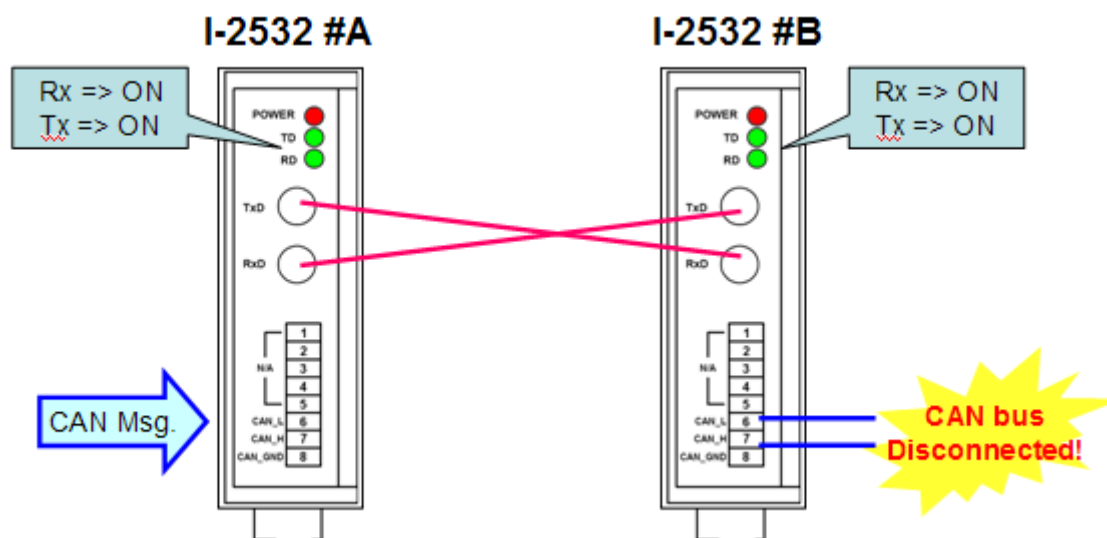

(3) One channel (Rx side) of the fiber cable is broken.

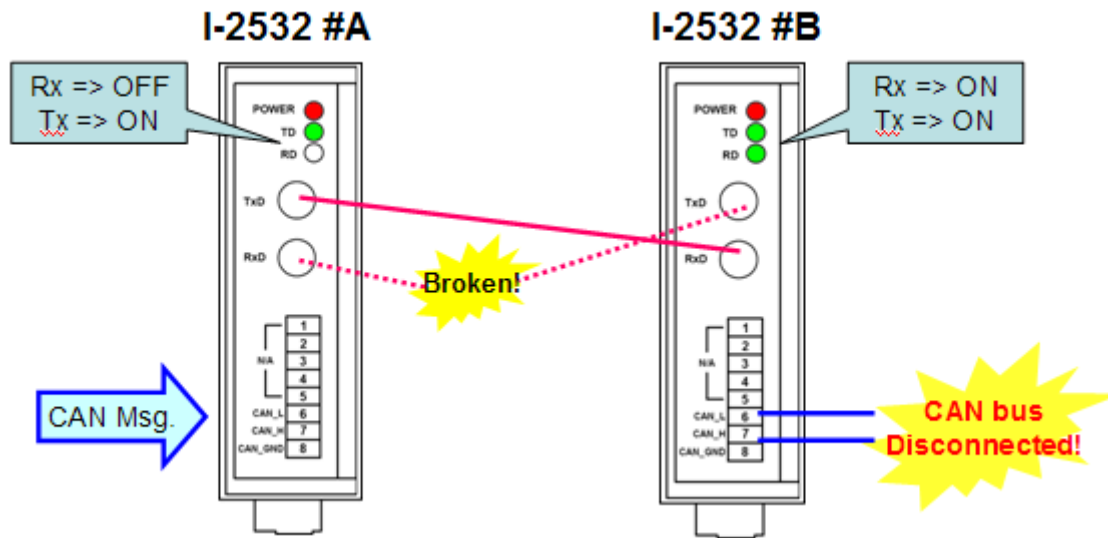

(4) One channel (Tx side) of the fiber cable is broken.

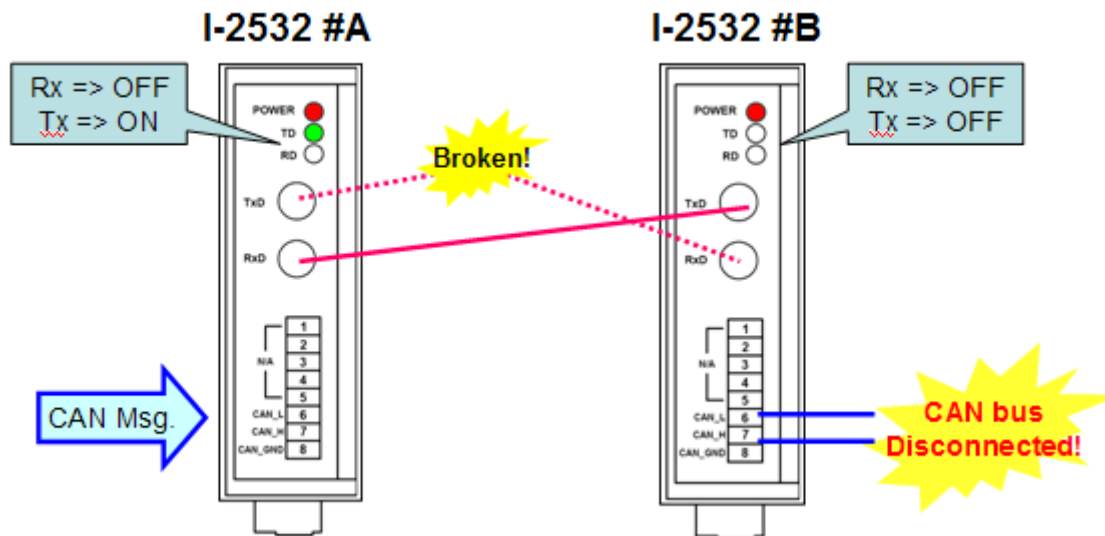

(5) Different CAN baud rate on the two I-2532 modules.

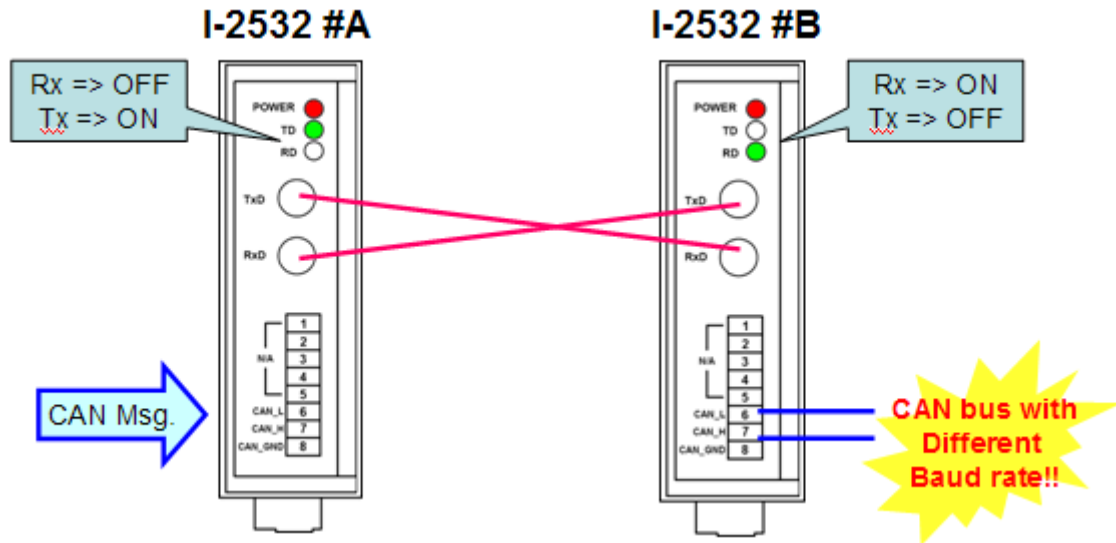

(2012/06/25, Johney)

Q8: Why the I-2532 modules stop to convert the CAN single to fiber single after a long time test? (2013/12/10, Alan)

A:

The I-2532 just converts electrical signal from CAN to fiber. When the power that supply to the I-2532 is no stable, it will make CAN bus signal level under CAN specification. At this situation, Error will be occurred on CAN bus and let CAN devices become bus off. (2013/12/10, Alan)